



GPM0001 E9171 GPU-based Processor Module

DO-254 Certifiable 3U VPX Graphics/Compute Module IP

Features and Benefits

- Part of the COTS-D family of safety certifiable modules
- A compact GPU Processing Module (GPM) providing up to five independent display outputs
- Eight compute units, each containing 64 shaders providing 1,248 GFLOPS FP32 (float) performance/ 78.02 GFLOPS FP64 (double) performance
- Single conduction-cooled rugged module - 3U VITA 65 (OpenVPX™) solution
- Option to incorporate either a standard VITA 61 XMC 2.0 site or a Personality Module using the Pn7 connector to reformat outputs and perform low latency sensor capture
- A complete hardware solution with data package to support certification to RTCA DO-254/EUROCAE ED-80
- The provision of all IP and data to enable manufacture, support, and repair of the module
- Availability of a certifiable OpenGL® and Vulkan®-based graphics and compute libraries with data packages to support DAL A certification to RTCA DO-178C/EUROCAE ED-12C



Introduction

The GPM0001, an AMD Embedded Radeon™ E9171-based 3U VPX GPU processing module (GPM), is ideal for avionics and defense applications requiring an optimal balance of performance and power efficiency, as well as high performance GPU processing and messaging with in-slot output formatting and video capture customization through a personality module.

The E9171 graphics design comes with all the data needed for support, manufacturing, and repair as well as data to support DO-254/ED-80 hardware certification. The GPM is also supported with compute, graphics, and video driver libraries complete with data to support DO-178C/ED-12C software certification. The available data kits support both FAA and EASA certification authority needs.

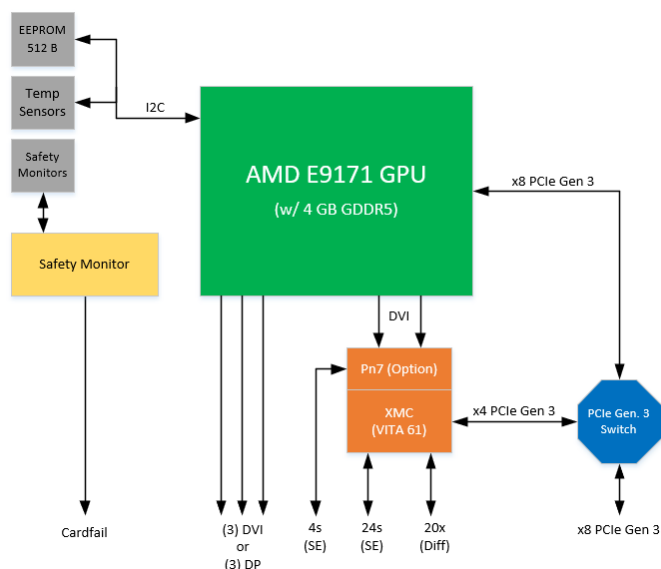

Figure 1: GPM0001 E9171 Block Diagram



The design includes the option to incorporate either a standard VITA 61 XMC 2.0 site or a Personality Module mezzanine (using the Pn7 connector), which enables video capture and GPU output format conversion. A Personality Module has the capability to reformat up to two independent outputs with the lowest latency into output formats required by the application such as HD-SDI, in order to have data ready to process and display in the GPU. In this configuration, some of the unused 3U VPX basecard I/O pins are made accessible to the personality module.

Processing

The Graphics Processing Unit (GPU) is the CoreAVI extended temperature screened AMD Embedded Radeon E9171, which is a discrete GPU in a multi-chip-module (MCM) format with integrated memory providing a smaller, power-efficient solution. The E9171 is the latest Embedded Radeon GPU from AMD offering twice the dedicated video memory and more than 2x the performance of the previous generation E8860 in the same power envelope. The E9171 also upgrades the video decode and encode for 4K support at 60 Hz and High Efficiency Video Coding (HVEC), H.265.

With integrated 4 GB of dedicated graphics memory and support for up to five simultaneous displays, the E9171 GPM virtually eliminates the need for additional processors and duplicate hardware to drive multiple displays with powerful applications.

The GPU is accessible through an eight lane PCIe gen 3 interface providing up to 7.88 GB/s bandwidth.

Memory

The GPM0001 E9171 GPM includes 4 GB of dedicated 128-bit wide GDDR5 SDRAM accessible from the PCIe interface through a 256 MB aperture (default can be configured via VBIOS), simplifying the mapping of one or more modules into an SBC PCI address space.

The dedicated graphics memory is used by the GPU and graphics driver libraries to store the frame buffers (the OpenGL rendered images), Vertex Buffer Objects (VBO) and OpenGL textures (application data such as moving map data or decoded video streams).



Figure 2: GPM0001 E9171-based COTS-D GPU-based Processor Module



Outputs

The following table summarizes the combination of outputs from the three display controllers to the backplane:

| Interface | Quantity |
|-----------------|---|
| DisplayPort 1.4 | Up to three 3840 x 2160 @ 60 Hz or 4096 x 2160 @ 60 Hz |
| Dual-link DVI | One 2560 x 1600 @ 60 Hz or 1920 x 1200 @ 60 Hz (maximum pixel rate: 330 MP/s for dual-link DVI) |
| Single-link DVI | Up to three 1920 x 1200 @ 60 Hz (maximum pixel rate: 165 MP/s (megapixels per second) for single-link DVI) |

Local Functions

Local functions include video decode acceleration and video encode acceleration.

The dedicated Unified Video Decoder hardware (UVD) provides the following video decoding features:

- H.264 decoding based on the ISO/IEC 14496-10 specification.
 - * Up to HP@ L5.1 decoding with a maximum bit rate of 160 Mbps. Support for constrained Baseline profile only (no FMO or ASO).
 - * Resolution support up to 4096 × 2160 (maximum 4K @ 60 fps).
- H.265 (HEVC) decoding based on the ISO/IEC 23008-2 specification.
 - * Up to Main/Main10 L5.1 decoding with a maximum bit rate of 160 Mbps.
 - * Resolution support up to 4096 × 2176 (maximum 4K @ 60 fps).

The dedicated Video Codec Engine (VCE) hardware provides the following video encoding features:

- H.264 encoding is based on the ISO/IEC 14496-10 specification.
 - * Up to Main Profile @ level 5.1 (3840 × 2160p @ 30 fps) I & P-frame (no B-frame) encode.
 - * Multi-stream support with total throughput up to 1080p @ 120 fps
 - * Constant bit rate and variable bit rate controls.
- H.265 (HEVC) encoding based on the ISO/IEC 23008-2 specification.
 - * Up to Main Profile @ level 5.0 High-Tier (4096 × 2160p @ 30fps) I and P frame (no B-frame) encode.
 - * Multi-stream support with total throughput up to 1080p @ 120 fps.
 - * Constant bit rate and variable bit rate controls.



Safety and Security Features

In addition, the module provides a suite of safety monitors to support safety requirements. These include temperature, voltage and clock monitors. The temperature monitor, E9171 internal thermal sensor, is under application control while voltage and clock out of range would result in the module being shut down. A failure of any of the monitors results in the assertion of a Card Fail indicator to the I/O connector.

Software

RTOS Board Support

The GPM0001 E9171 GPM is fully supported by a suite of graphics and video libraries with support for leading RTOS and Single Board Computer hosts, like CoreAVI's SBC0003 LX2080A SBC. CoreAVI is able to provide a complete DO-178C/ED-12C certifiable software package including the Real Time Operating System and its artifacts, certifiable Built-In-Test (BIT) Software, certifiable graphics drivers – all pre-integrated and ready to go. As the single provider of the entire software suite, support is easy to obtain and CoreAVI's expertise in software certification ensures the lowest risk. Please contact CoreAVI for additional RTOS support.

- DDC-I Deos™
- Lynx Software LynxOS®-178
- SYSGO PikeOS®

CoreAVI also provides support for Green Hills® INTEGRITY® and Wind River® VxWorks® RTOS. Please contact CoreAVI for more details.

This diagram provides an overview of the available driver libraries which are described in the following sections. Further information and data sheets are available on CoreAVI's website.

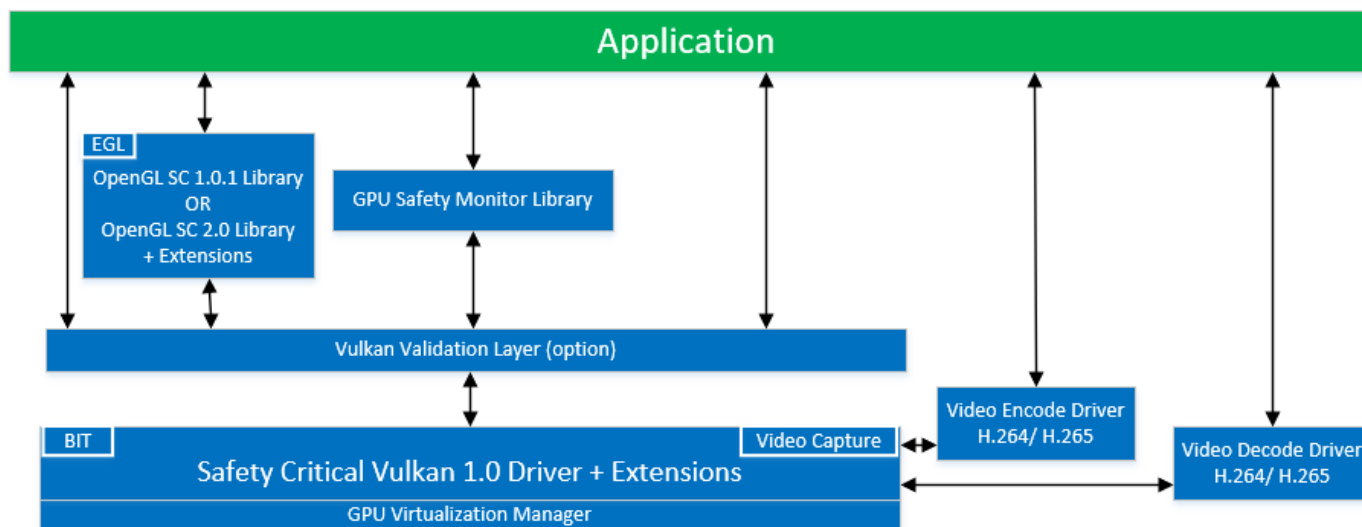

Figure 3: E9171 Software Overview



Vulkan

The foundation for the E9171 graphics support is CoreAVI's VkCore® SC safety critical Vulkan-based graphics and compute driver. VkCore SC provides programmable graphics pipeline rendering enabling application flexibility by making use of the programmable units within the E9171 GPU. Vulkan is a thin low-overhead graphics and compute API targeting high performance applications by offering higher performance than OpenGL as well as a more balanced CPU/GPU usage. CoreAVI supports Vulkan with graphics and compute libraries for common tasks and algorithms, allowing customers to focus on the application. In addition, CoreAVI provides VkCoreGL™ SC 1.0.1 and VkCoreGL SC 2.0 application libraries for our VkCore SC driver, enabling customers to take advantage of Vulkan for existing applications to address performance-bound areas and add new capabilities.

There is an included compositor extension in the VkCoreGL SC libraries called EGL_EXT_compositor to composite and display multiple off-screen graphics frame buffers. VkCore SC and the EGL_EXT_compositor provide an aligned solution for all Future Airborne Capability Environment (FACE™) profiles.

CoreAVI's VkCore SC Vulkan-based solution also supports multi-partition and multi-threaded applications.

Video

The dedicated Unified Video Decoder hardware (UVD) is supported by CoreAVI's DecodeCore™ driver library. DecodeCore supports H.264 and H.265 video decoding of up to ten streams placing the decoded video data directly into OpenGL textures ready for complex hardware accelerated image manipulation and integration with 2D or 3D graphics. The driver architecture and API ensure high efficiency and low latency between the video decode hardware and the graphics hardware.

The dedicated Video Codec Engine (VCE) hardware is supported by CoreAVI's EncodeCore™ driver library. EncodeCore can encode video data on the SBC host or directly encode a frame buffer within the GPU providing either an H.264 or H.265 raw encoded video stream available on the SBC host. The encoding of a frame buffer is particularly useful for distributing and/or recording the data being presented on a display.

CoreAVI also includes a video capture API with the graphics driver library. VkCore SC works with DMA engines to provide a semi-autonomous mechanism to directly capture video input to GPU memory as an OpenGL texture, minimizing latency.

GPU Software Safety Monitor

To address safety requirements with respect to preventing or detecting the potential display of Hazardously Misleading Information (HMI), CoreAVI's TrueCore™ GPU safety monitor provides a software approach to detecting E9171 failures that may lead to HMI.

Rear Transition Module (RTM)

For development purposes a RTM is available that plugs into the backside of the backplane in the same slot as the E9171 processor. The RTM provides access to the E9171 GPM's I/O through commercial industry standard connectors, headers and cables.



Lifecycle

AMD has planned a seven-year availability of the E9171 to the end of 2024, making it one of the longest available GPUs on the market today. CoreAVI offers a long term supply program to extend the availability of our supported GPUs past the Last Time Buy date set by the manufacturer. Please contact CoreAVI for more details.

Component Supply

Similar to the successfully qualified and deployed CoreAVI extended temperature screened E4690 and E8860 GPUs, the E9171 is also extended temperature screened by CoreAVI to enable applications to use the GPU in harsh operating conditions.

Specifications

The GPM0001 E9171 GPM is designed to run from the +5V rail (VS3) with maximum typical current per the following table based on the execution of a representative application at the highest rated operating temperature. The VkCore SC graphics driver includes power management support to configure the GPU to balance application and power requirements.

| Voltage | Typical Current (Amps) |
|-----------------|--------------------------------|
| +12V | Only if required by XMC module |
| -12V | Only if required by XMC module |
| +5V | 10 |
| +12V Auxiliary | Not used |
| -12V Auxiliary | Not used |
| +3.3V Auxiliary | 0.1 |

The GPM0001 E9171 GPM's dimensions are per VITA 46/IEEE 1101.2 for a 1.0" pitch conduction-cooled module. The weight is less than 700 grams. Environmental specifications are per the following table:

| Environment | Specification |
|-----------------------|--|
| Operating Temperature | -40° to +85° C at module edge |
| Storage Temperature | -55° to 105° C |
| Vibration | 0.1 g ² /Hz (max), 5 to 2000 Hz |
| Shock | 40 g. 11ms sawtooth |
| Humidity | 0% to 95% non-condensing (dependent on conformal coating used) |



The E9171 GPM is compatible with the following VITA 65 slot profiles:

- MOD3-PAY-2F
- MOD3-PER-2F

COTS-D Data Kit

The COTS-D kit provides all the data to enable support, manufacturing and repair of the E9171 GPM. Key elements of the data package include:

- Theory of Operations
- Bill of Materials including full manufacturers part numbers
- Schematics
- Mechanical drawings and assembly diagrams
- Printed Circuit Board (PCB) drawings and data
- Manufacturing data
- Qualification data

The technical transfer also includes training and support for the product introduction process at your manufacturing facility or chosen contract manufacturer. Please request the COTS-D application note which provides further details on the data items and support provided for the technical transfer.

DO-254/ED-80/ARP4761 Data Kit

The DO-254/ED-80/ARP4761 Data Kit provides documentation and evidence to support FAA and EASA certification requirements of the hardware elements as well as Failure Modes and Effects Analysis (FMEA) and other documentation to support ARP4761 safety assessments for the E9171 GPM—specifically, data for the E9171 to support Design Assurance Level (DAL) A.

DO-178C/ED-12C Data Kit

The DO-178C/ED-12C Data Kit provides documentation and evidence to support FAA and EASA certification requirements of the software elements up to and including Level A.



Ordering

The following GPM0001 E9171 GPM products can be ordered from CoreAVI:

- E9171 GPM for development purposes
- COTS-D Design/Manufacturing Data Kit and license to use
- Safety Critical Data Kit supporting DO-254/ED-80/ARP4761
- VkCore SC graphics and compute driver
- VkCoreGL SC 1.0.1 and VkCoreGL SC 2.0 application libraries with EGL_EXT_compositor
- DecodeCore driver
- EncodeCore driver
- TrueCore application library
- DO-178C/ED-12C Level A Data Kit for each of the driver and libraries

Contact CoreAVI to discuss your requirements and obtain a quote.